

mounting direction

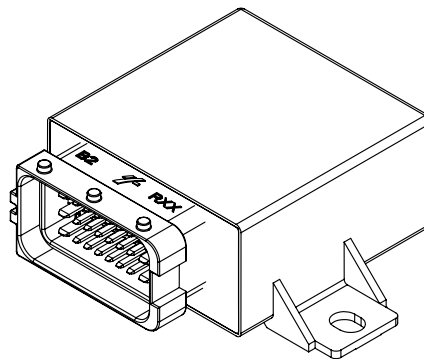

view of plug

DESCRIPTION

The waterproof CAN I/O PLC Waterproof PRO V2 with 16 inputs and outputs convinces by the various application possibilities in numerous control applications. In addition to eight I/Os that can be configured as inputs or outputs, it offers six analog and two digital inputs.

TECHNICAL DATA

Housing	Moulded plastic, sealed
Connector	Sicma 211 PL249S0005
Housing dimension	60 x 60 x 30 mm (without tabs and connector) 95 x 77.3 x 33.5 mm (incl. tabs and connector)
Weight	167 g
Temperature range (ISO 16750-4 compliant)	-40 to +85 °C (at +85 °C rated power see page 4)
Environmental protection	IP6K6 und IP 6K8
Current consumption	30 mA
Over-current protection	20 A
Total inputs and outputs	16 (6 Analogeingänge, 8 I/O's, 2 Digitaleingänge)
Inputs	Configurable as: Digital, positive encoder signal Analog input (0... 11.3 V) Digital, low side switch encoder signal Analog input (0...23 mA, 10 kΩ Pull-up)
Outputs	Configurable as: Digital output, positive switching (high side) PWM output (3 Hz...500 Hz)
Operating voltage	9–32 V 12 V (code B) and 24 V (code E) ISO 16750–2 compliant
Starting voltage	8 V
Overvoltage protection	≥ 33 V
Undervoltage cut-off	8 V
Quiescent current	138 µA (at 24 V); 875 µA (at 12 V)
Reverse polarity protection	Yes
CAN interfaces	CAN bus interface 2.0 A/B, ISO 11898-2 compliant
Baudrate	60 kbps – 1000 kbps Standard: 125 kbps

REGULATORY APPROVALS AND TESTING

E1 label	UN/ECE-R10 04
CE conformity	Konform
E1 approval	05 7992
Electrical tests	According to ISO 16750 – 2/ 16750-4: Short circuit protection (except RS232 interface) Reversed voltage Pin/connector interruption Overvoltage at +65 °C Operation/storage test at +85 °C Operation/storage test at -40 °C Superimposed alternating voltage Slow decrease and increase of supply voltage Momentary drop in supply voltage Reset behavior at voltage drop Tests According to ISO 7637 - 2: Pulse 1, 2a, 2b, 3a, 3b

SOFTWARE/PROGRAMMING

Programming System	MRS Developers Studio MRS Developers Studio with built-in functions library, similar to programming with FUP. Custom software blocks can be integrated into "C-code". Program memory is sufficient for about 300 basic logic components.
--------------------	--



INPUT FEATURES - SUMMARY

Pin A3, A4, A5, A6, B6, C4	Analog inputs Resolution	12 Bit	Pin B3, B5	Digital input Resolution	12 Bit
Voltage input 0...11.3 V (see A)	Input resistance Input frequency Accuracy	22,6 kΩ f _g ¹ = 70 Hz ± 3 %	Digital input positive (see E)	Turn-on threshold Turn-off threshold	6,6 V 4,7 V
Current input 0...23 mA (see B)	Input resistance Conversion factor	500 Ω 1 mA ≈ 480 ± 3 Digits	Pin B1, B8, C1, C2, C3, C8	I/Os Resolution	12 Bit
Pull-Up input (see C)	Pull-up resistance	10 kΩ	Voltage input 0...11.3 V (see E)	Input resistance Input frequency Accuracy	15 kΩ f _g ¹ = 70 Hz ± 3 %
¹ cutoff frequency (-3 dB)			Pin C6, C7	I/Os Auflösung Accuracy	12 Bit ± 1 % full scale
			Voltage input 0...11.3 V (see E)	Input resistance Input frequency	15 kΩ f _g ¹ = 70 Hz

OUTPUT FEATURES - SUMMARY

Pin C6, C7	Protective circuit for inductive loads Wire fault diagnostics Short circuit diagnostics	Optionally integrated Possible via current sense Possible via current sense	Pin B1, B8, C1, C2, C3, C8	Protective circuit for inductive loads Wire fault diagnostics Short circuit diagnostics	Optionally integrated Possible via current sense Possible via current sense
Digital, positive switching (high side, see E)	Switching voltage Switching current	9-32 V DC 0,02-2,5 A	Digital, positive switching (high side, see E)	Switching voltage Switching current Conversion factor current sense pins B1, C1, C2, C3 Conversion factor current sense pins B8, C6, C7, C8	9-32 V DC 0,02-2,5 A 1 Digit ± 2,2± 0,1 mA 1 Digit ± 1,2± 0,1 mA
Short circuit resistance against GND and V _B	Switching-off is controlled by high side driver (separate for each channel)		PWM-output (see G)	Output frequency Duty cycle Resolution Switching current	500 Hz 0...1000 % 1 ‰ ≤ 2,5A (see page 4)
Pin A7 5 V Output	Max. switching current	500 mA	Short circuit resistance against GND and V _B	Switching-off is controlled by high side driver (separate for each channel)	
			Exception PIN B1, C1, C2, C3	Current sense of output current via AI_INA_PWM	

PIN ASSIGNMENT POWER SUPPLY AND INTERFACES

Pin	Description	Pin	Description
A1	Supply voltage for output pins B1, C1, C2, C3 operating voltage for CPU	B2	RS-485 - B / RS-232 Rx interface (assembly option see page 5)
A2	RS-485 - A / RS-232 Tx interface (assembly option see page 5)	B4	CAN bus high
A7	5 V VREF	B5	Battery/ignition contact 15 according to DIN 72552, optional as DI (see page 5)
A8	Supply voltage for output pins B8, C6, C7, C8, operating voltage for CPU	B7	Ground/contact 31 according to DIN 72552
		C5	CAN bus low

PIN ASSIGNMENT INPUTS AND OUTPUTS

Pin	Signal	Description	Pin	Signal	Description
A3	AI5 DO_PU5 DO_PD5	Analog input 5; 0-11.3 V can also be used as: 10 kΩ pull-up Current sense 23 mA	B8	AI_U_PWM4 DO_PWM4	Analog input 4; 0-11.3 V can also be used as digital output with PWM capability
A4	AI4 DO_PU4 DO_PD4	Analog input 4; 0-11.3 V can also be used as: 10 kΩ pull-up Current sense 23 mA	C1	AI_U_PWM2 DO_PWM2	Analog input 2; 0-11.3 V can also be used as digital output with PWM capability
A5	AI2 DO_PU2 DO_PD2	Analog input 2; 0-11.3 V can also be used as: 10 kΩ pull-up Current sense 24.5 mA	C2	AI_U_PWM1 DO_PWM1	Analog input 1; 0-11.3 V can also be used as digital output with PWM capability
A6	AI1 DO_PU1 DO_PD1	Analog input 1; 0-11.3 V can also be used as: 10 kΩ pull-up Current sense 23 mA	C3	AI_U_PWM0 DO_PWM0	Analog input 0; 0-11.3 V can also be used as digital output with PWM capability
B1	AI_U_PWM3 DO_PWM3	Analog input 3; 0-11.3 V can also be used as digital output with PWM capability	C4	AI3 DO_PU3 DO_PD3	Analog input 3; 0-11.3 V can also be used as: 10 kΩ Pull-Up Current sense 23 mA
B3	DI_ID	Digital input	C6	AI_U_DO1 DO_OUT1	Analog input 1; 0-11.3 V can also be used as digital output
B6	AI0 DO_PU0 DO_PD0	Analog input 0; 0-11.3 V can also be used as: 10 kΩ pull-up Current sense 23 mA	C7	AI_U_DO0 DO_OUT0	Analog input 0; 0-11.3 V can also be used as digital output
			C8	AI_U_PWM5 DO_PWM5	Analog input 5; 0-11.3 V can also be used as digital output with PWM capability

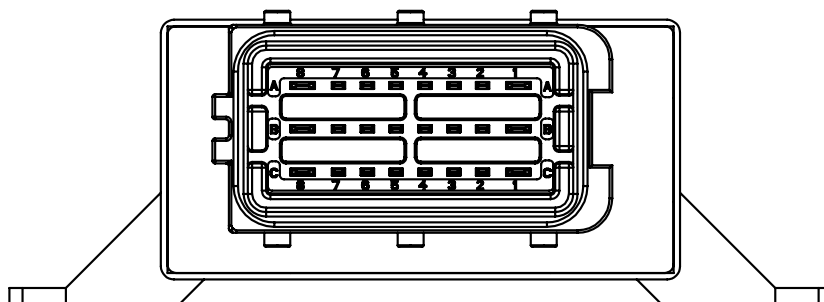



PIN FEATURE MAP

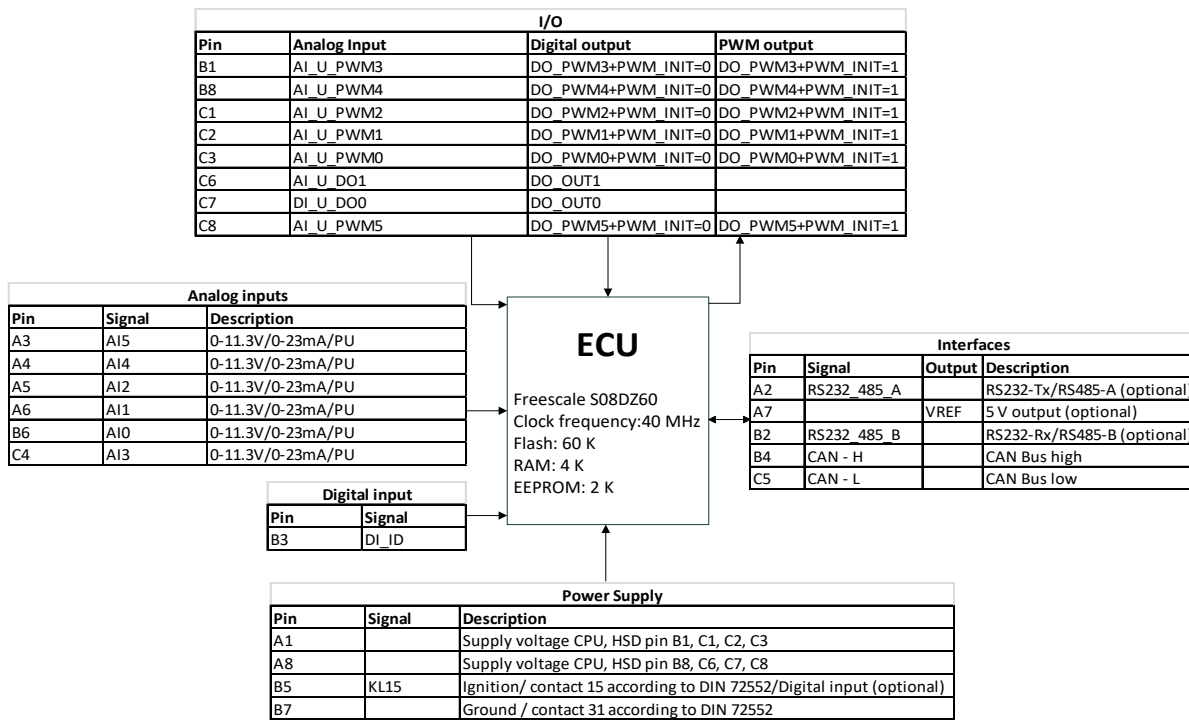

PERFORMANCE TESTS HIGH SIDE DRIVER VNQ5050AK

Test without PWM

	Test No.	Load	Endurance
Endurance tests at +80 °C for digital outputs	1	4 x 2,5 A	Continuous
	2	3 x 2,5 A 1 x 3,5 A	30 minutes
(max. 2 channels per high side driver)	3	2 x 2,5 A 2 x 3,5 A	15 minutes
	4	1 x 2,5 A 3 x 3,5 A	10 minutes
	5	2 x 5 A	5 minutes

Test with PWM

	Test Nr.	Load	Endurance
Endurance tests at +80 °C for PWM outputs with frequency=200 Hz and 90 % duty cycle	1	4 x 2,0 A	Continuous
	2	4 x 2,5 A	15 minutes
(max. 2 channels per high side driver)	3	1 x 3,5 A 3 x 2,5 A	2 minutes
	4	2 x 3,5 A	2 minutes

BLOCK FUNCTION DIAGRAM

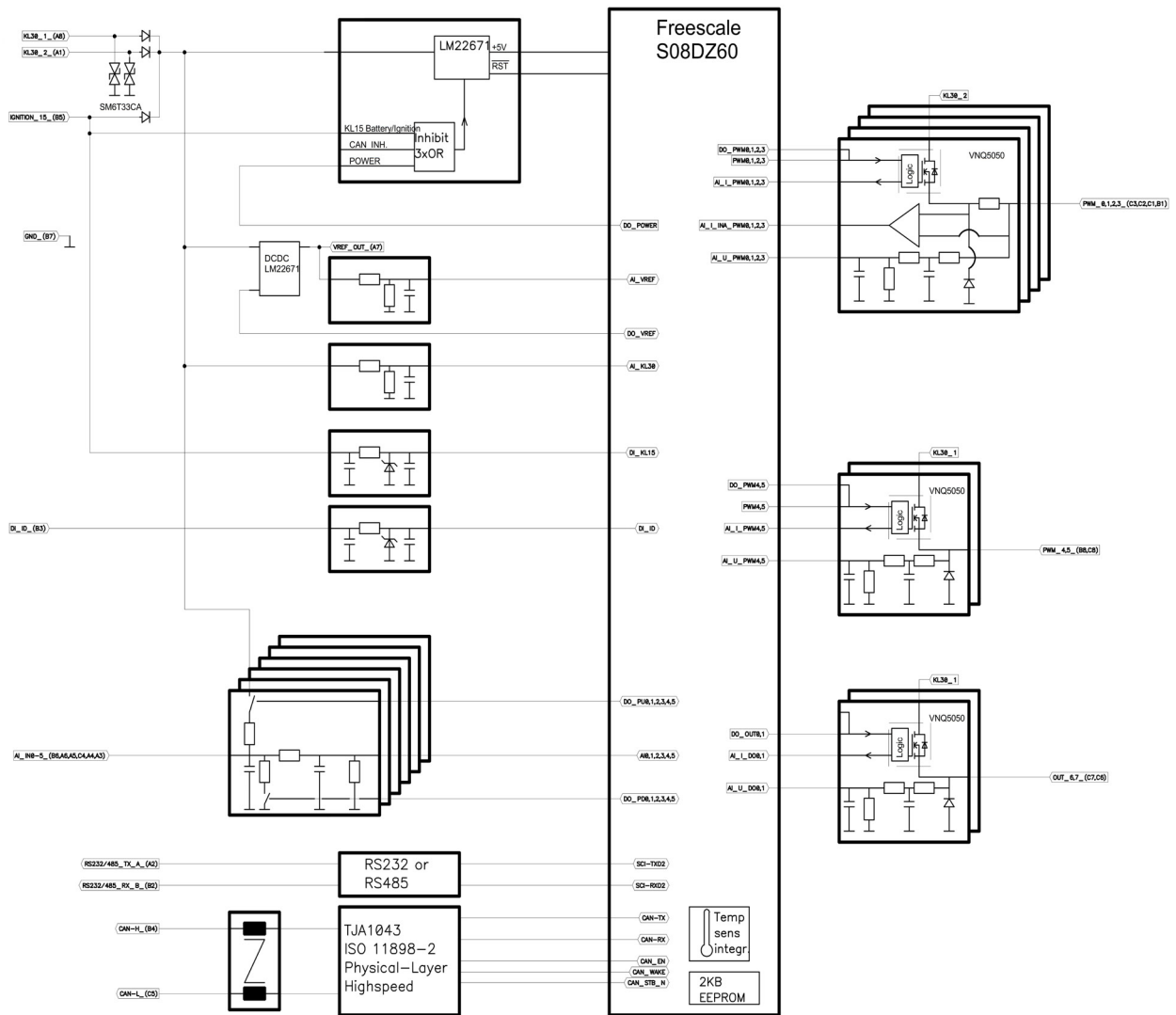

BLOCK FUNCTION DIAGRAM FOR ASSEMBLY OPTIONS

Current input

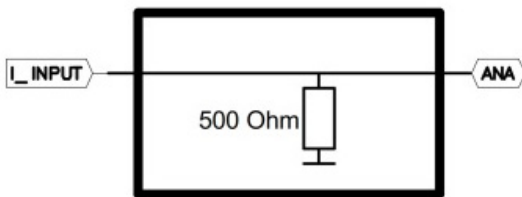

Pull-up input

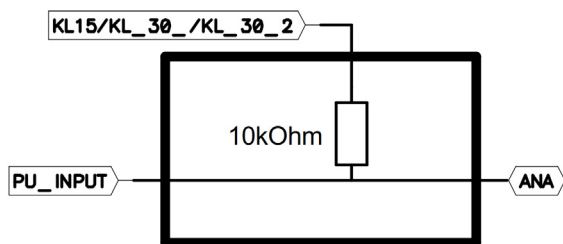

TECHNICAL DRAWING (IN MM)

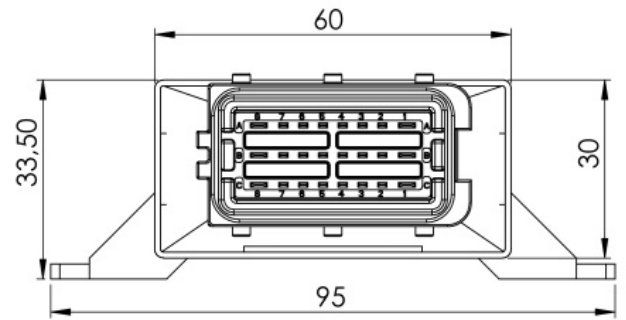
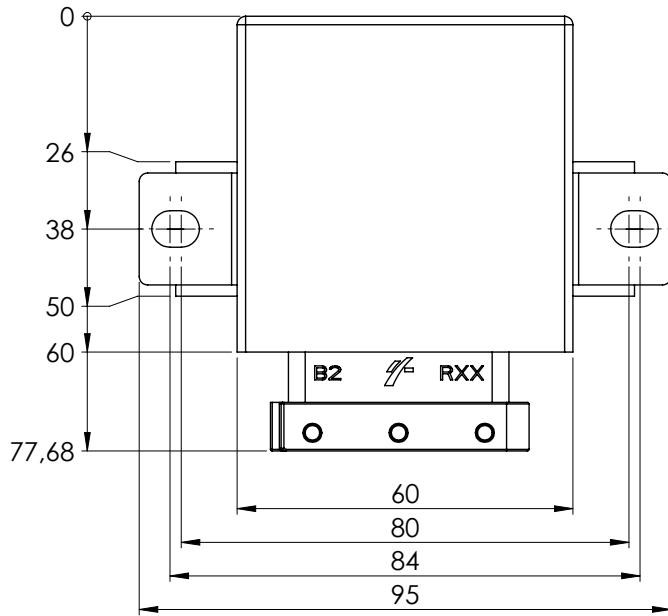



ASSEMBLY OPTIONS AND ORDER INFORMATION

Order number	Inputs						Outputs G PWM ≤ 500 Hz	CAN Bus		Wake up	Serial interface		5 V Output	µC
	A voltage 0 – 11.3 V	B current 0 – 23 mA	C Sensor inputs 10 kΩ Pull-up	D Frecu-ency input	E Digital input	F I/O's (can be used as analog or digital input o ras digital output)		High-Speed	Low-Speed		RS485	RS232		
1.128.301.0000	A3, A4, A5, A6, B6, C4	A3, A4, A5, A6, B6, C4	A3, A4, A5, A6, B6, C4		B3	B1, B8, C1, C2, C3, C6, C7, C8	B1, B8, C1, C2, C3, C8	X		KL 30		X	X	DZ60
1.128.301.1000	A3, A4, A5, A6, B6, C4	A3, A4, A5, A6, B6, C4	A3, A4, A5, A6, B6, C4		B3	B1, B8, C1, C2, C3, C6, C7, C8	B1, B8, C1, C2, C3, C8	X		KL 15/ CAN		X	X	DZ60
1.128.321.1000	A3, A4, A5, A6, B6, C4	A3, A4, A5, A6, B6, C4	A3, A4, A5, A6, B6, C4		B3	B1, B8, C1, C2, C3, C6, C7, C8	B1, B8, C1, C2, C3, C8	X		KL 15/ CAN	X		X	DZ60
1.128.301.1010	A3, A4, A5, A6, B6, C4	A3, A4, A5, A6, B6, C4	A3, A4, A5, A6, B6, C4		B3	B1, B8, C1, C2, C3, C6, C7, C8	B1, B8, C1, C2, C3, C8	X		KL 15/ CAN		X	X	DZ128
1.128P.301.1000 (CANopen)	A3, A4, A5, A6, B6, C4	A3, A4, A5, A6, B6, C4	A3, A4, A5, A6, B6, C4		B3	B1, B8, C1, C2, C3, C6, C7, C8	B1, B8, C1, C2, C3, C8	X		KL 15/ CAN		X	X	DZ60

ACCESSORIES

Description	Order number
Programming tool MRS Developers Studio	1.100.100.09
Programming Cable set CAN I/O WP	110490
Connector package CAN I/O WP	110421
Rubber boot for cable set	102892
PCAN-USB Interface	105358
Crimp terminals 2.8 mm/1-2.5 mm ²	109947
Crimp terminals 1.5 mm/1.3-2. mm ²	109949
Dummy FCI Filler Plug	110268



MANUFACTURER

MRS Electronic GmbH & Co. KG
 Klaus-Gutsch-Str. 7
 78628 Rottweil

NOTES ON WIRING AND CABLE ROUTING

The electronic system and the power outputs of a control unit must be supplied by the same power supply system.

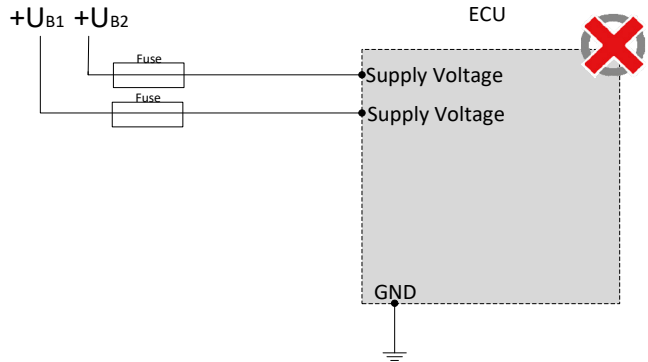
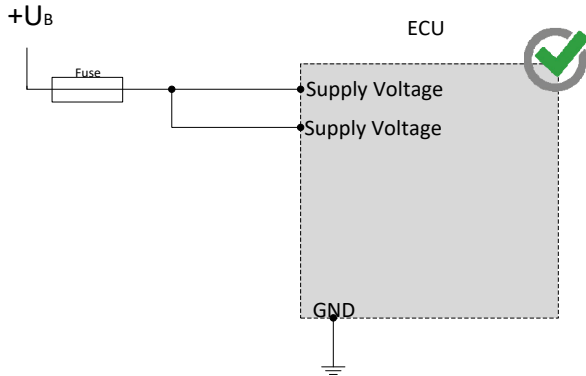

PWM outputs may not be connected with each other or bypassed.

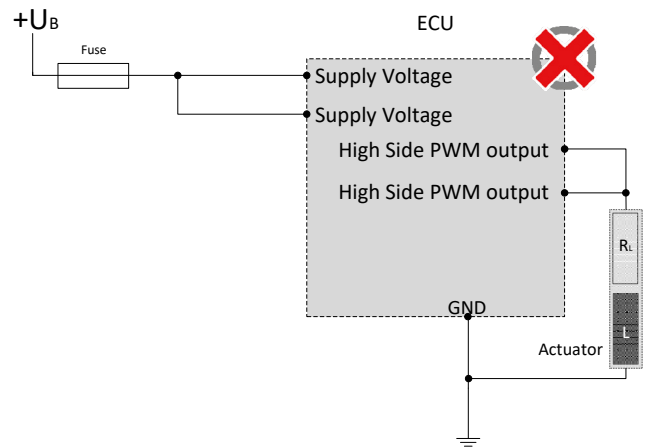
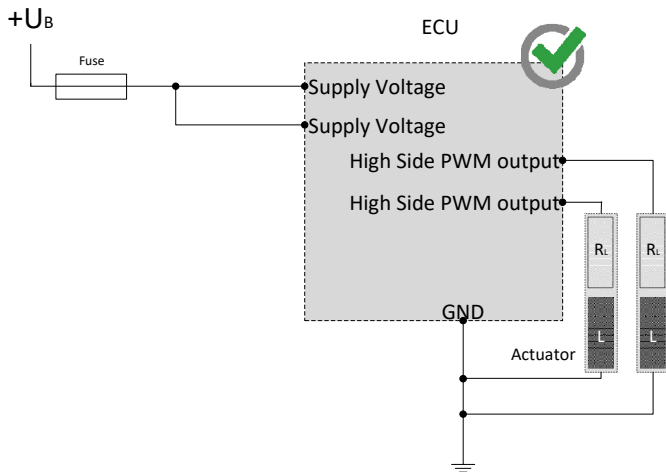

The pins (I/Os) can be used in combination and may not be switched externally against a higher voltage level than supply voltage.

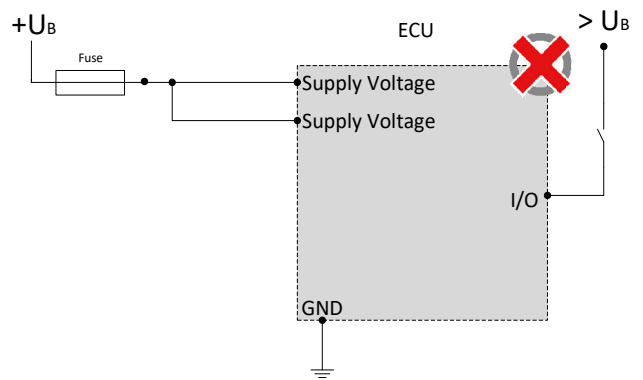
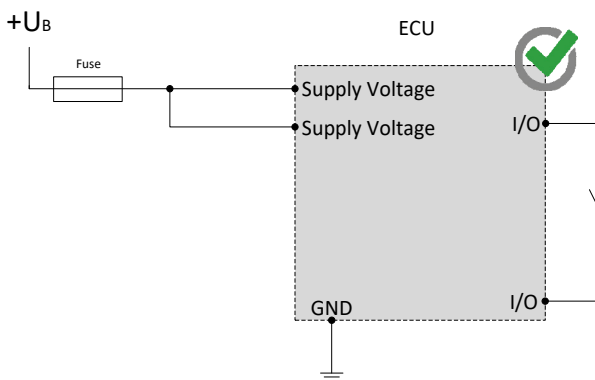

NOTES ON WIRING AND CABLE ROUTING

Hightside outputs may only be switched to ground.

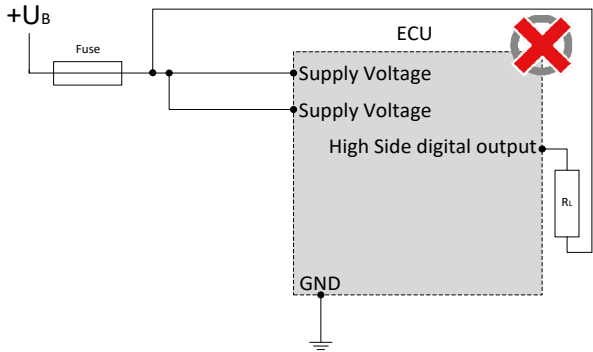
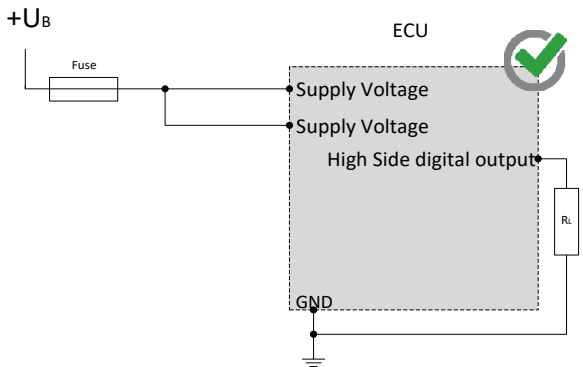
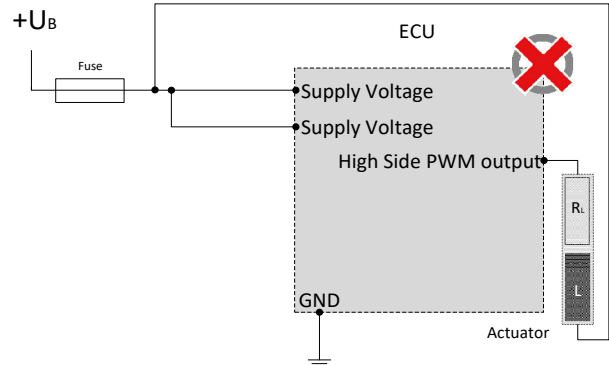
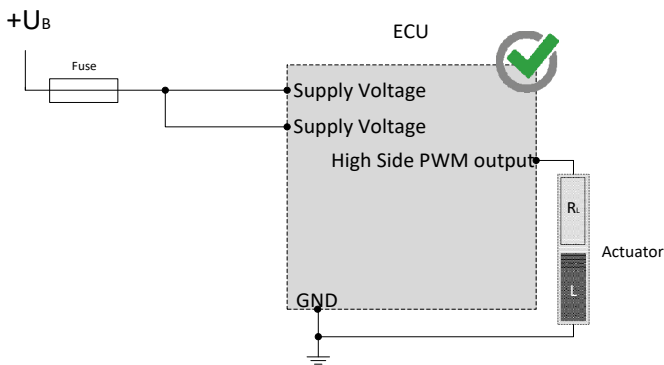

The sensor supplies can be "lifted" through an external circuitry, for example the creation of higher voltage, as they only work as a voltage source but not as voltage drain. The lift of a voltage source may lead to unforeseen malfunctions and damages of the control unit in case of permanent operation.

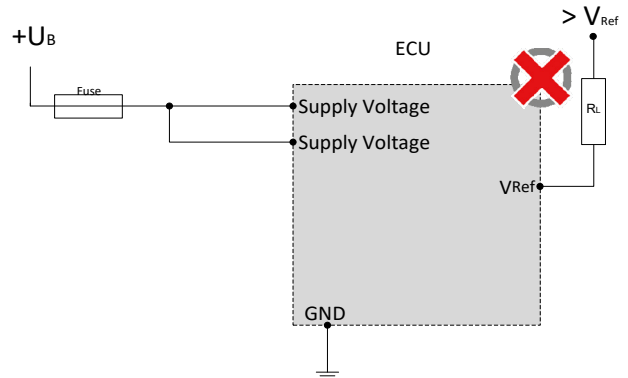
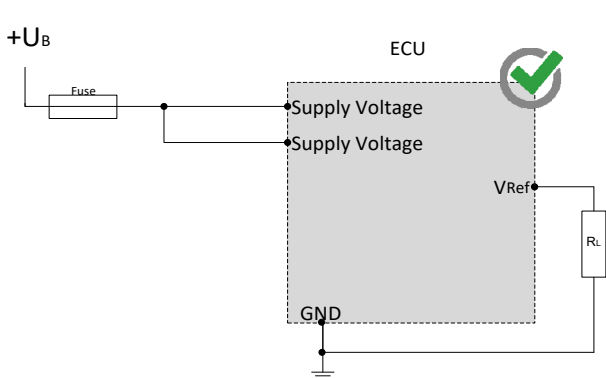

CAN bus communication is the main communication between the control unit and the vehicle. Therefore, connect the CAN bus with special care and check the correct communication with the vehicle to avoid undesired behavior.

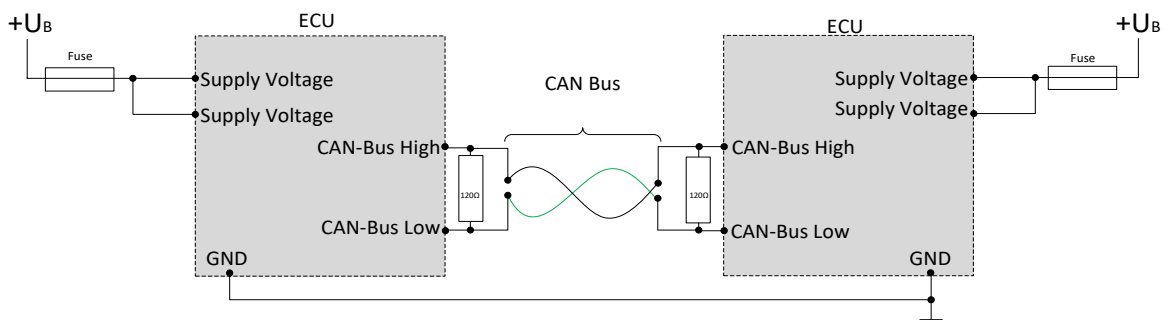

SAFETY AND INSTALLATION INFORMATION

It is essential to read the instructions in full thoroughly before working with the device.

Please note and comply with the instructions in the operating instructions and the information in the device data sheet, see www.mrs-electronic.de

Staff qualification: Only staff with the appropriate qualifications may work on this device or in its proximity.

SAFETY

⚠ WARNING! Danger as a result of a malfunction of the entire system.
Unforeseen reactions or malfunctions of the entire system may jeopardise the safety of people or the machine.

- Ensure that the device is equipped with the correct software and that the wiring and settings on the hardware are appropriate.

⚠ WARNING! Danger as a result of unprotected moving components.
Unforeseen dangers may occur from the entire system when putting the device into operation and maintaining it.

- Switch the entire system off before carrying out any work and prevent it from unintentionally switching back on.
- Before putting the device into operation, ensure that the entire system and parts of the system are safe.
- The device should never be connected or separated under load or voltage.

⚠ CAUTION! Risk of burns from the housing.
The temperature of the device housing may be elevated.

- Do not touch the housing and let all system components cool before working on the system.

PROPER USE

The device is used to control or switch one or more electrical systems or sub-systems in motor vehicles and machines and may only be used for this purpose. The device may only be used in an industrial setting.

⚠ WARNING! Danger caused by incorrect use.
The device is only intended for use in motor vehicles and machines.

- Use in safety-related system parts for personal protection is not permitted.
- Do not use the device in areas where there is a risk of explosion.

Correct use:

- operating the device within the operating areas specified and approved in the associated data sheet.
- strict compliance with these instructions and no other actions which may jeopardise the safety of individuals or the functionality of the device.

Obligations of the manufacturer of entire systems

It is necessary to ensure that only functional devices are used. If devices fail or malfunction, they must be replaced immediately.

System developments, installation and the putting into operation of electrical systems may only be carried out by trained and experienced staff who are sufficiently familiar with the handling of the components used and the entire system.

It is necessary to ensure that the wiring and programming of the device does not lead to safety-related malfunctions of the entire system in the event of a failure or a malfunction. System behaviour of this type can lead to a danger to life or high levels of material damage.

The manufacturer of the entire system is responsible for the correct connection of the entire periphery (e.g. cable cross sections, correct selection/connection of sensors/actuators).

Opening the device, making changes to the device and carrying out repairs are all prohibited. Changes or repairs made to the cabling can lead to dangerous malfunctions. Repairs may only be carried out by MRS.

Installation

The installation location must be selected so the device is exposed to as low a mechanical and thermal load as possible. The device may not be exposed to any chemical loads.

Install the device in such a manner that the plugs point downwards. This means condensation can flow off the device. Single seals on the cables/leads must be used to ensure that no water gets into the device.

Putting into operation

The device may only be put into operation by qualified staff. This may only occur when the status of the entire system corresponds to the applicable guidelines and regulations.

FAULT CORRECTION AND MAINTENANCE

i NOTE The device is maintenance-free and may not be opened.

- If the device has damage to the housing, latches, seals or flat plugs, it must be taken out of operation.

Fault correction and cleaning work may only be carried out with the power turned off. Remove the device to correct faults and to clean it.

Check the integrity of the housing and all flat plugs, connections and pins for mechanical damage, damage caused by overheating, insulation damage and corrosion. In the event of faulty switching, check the software, switches and settings.

Do not clean the device with high pressure cleaners or steam jets. Do not use aggressive solvents or abrasive substances.